

D+100 90° Tru-Bore® Metric Elbow

A D+100 90° Tru-Bore® metric elbow is a type of butt weld fitting that can connect two equally sized metric pipes. It is manufactured from either tubes, sheet or strip depending on the specific product and dimension required.

The stainless steel welded D+100 90° Tru-Bore® metric elbow for Pressure Purposes that Special Metric Materials typically supplies are manufactured to EN 10253-4/EN 10253-3. Elbows manufactured to EN 10253-4 have a weld factor of $z=1$ & are rated to a higher pressure capability.

Special Metric Materials can supply stainless steel welded D+100 90° Tru-Bore® metric elbows in the following Grades: 304L (1.4307), 316L (1.4404) & 316L High Moly (1.4432).

Tru-Bore® is a registered trademark of OSTP.

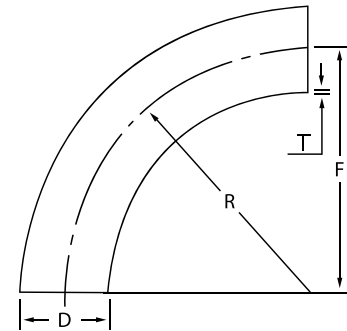

DN=ID	D	R	2	2.5	3	4
40	44.5	140	0.4			
50	54	150	0.5			
65	69	165	0.9			
80	84	180	1.2			
100	104/106	200	1.6		2.4	
125	129/131	225	2.4		3.5	
150	154/156/158	250	3.1		4.6	6.1
	160/162					
200	204/205/206	300	4.8	6	7.3	
	208/210					9.7
250	254/255/256	350	7	8.7	10.5	
	258/260					14
300	304/305/306	400	9.6	12	14.4	
	306/308/310				14.4	19.2
350	355/356/358	450		16	19	25
	360/362					
400	406/408	500			24	32
	410/412					
450	456/458	550			30	40
	460/462					
500	506/508	600			37	48
	510/512					
600	606/608	700			49	66
	610/612					
700	708/710/712	800				89
800	808/810/812	900				115
900	908/910/912	1000				143
1000	1010/1012	1100				